



# Air Velocity Monitor

## Model - 102

Save Energy | Enhance Safety

## Syannlab Solutions Pvt. Ltd.

No. 698, 1<sup>st</sup> Floor, 5<sup>th</sup> Block, SMV Layout Ullalu Upanagara, Bengaluru - 560056  
Ph +91 95919 89760 | info@syannlab.com | www.syannlab.com

 [instagram.com/syannlabs](https://www.instagram.com/syannlabs)  [x.com/syannlab](https://x.com/syannlab)  [linkedin.com/company/syannlab](https://www.linkedin.com/company/syannlab)  
 [facebook.com/syannlabs](https://www.facebook.com/syannlabs)  [youtube.com/@syannlab](https://www.youtube.com/@syannlab)

# Air Velocity Monitor

Model : 102

Microcontroller based face velocity measurement device with the unidirectional flow sensor, measurement against set point and indication of high or low value. Alert with audio visible alarm when out of range of velocity and for the reverse direction airflow. The device is with glass front and features touch buttons interface and relays for controlling light and exhaust fan contactor. The illuminated digital OLED display 1.3 inch shows the operating status and the face velocity as a numeric value in SI and Imperial system.

## FEATURES:

- ASHRAE 110 - 2016 Ready
- Display - Illuminated OLED, 1.3inch
- Visual Indication - Bright LED Green and Red
- Audible Indication - up to 60dB sound level
- Input - 5 capacitive touch button input for Menu, Mute, Up/Down, Light and Fan
- Power supply - 230V AC power adaptor, Power usage - 24VDC 1A
- Display unit - SI (MKS) & Imperial (FPS)
- Measurement type - Directional type (inwards only)
- Measurement range - 0 to 2 m/s (truncated)
- Measurement list count - 0.01 m/s (1 fpm)
- Velocity accuracy - 3% FS \*
- System repeatability - 3%\*
- Response time - 1 seconds (truncated)
- Alarm silence - Temporary, programmable duration
- Alarm repeat - Repeated alarm with programmable time
- Calibration adviser - 4000 hrs preset, programmable & resettable
- Control - Light and Fan, On & Off thru contactor relay 1A
- Communication - Digital NO NC for velocity fault
- Communication - Velocity analogue output 0(2)-10 V or 4-20 mA optional
- Buzzer volume - High & low user settable.
- Mounting - Semi flush, M3 screws
- Operating temperature - 10°C to 40°C
- Operating Humidity - 25% to 75% RH
- Device outer dimension - 145 x 82 x 56 mm
- Cut-out size - 112 x 70 mm, Fixing hole pitch - 135 mm

## Air Velocity Monitor

Model : 102



### Tender Specification:

102 - Air Velocity Monitor

**Make:** Syannlab Solutions Pvt. Ltd.

The Airflow Monitor accurately measures and displays airflow velocity across the hood sash on a bright 1.3" OLED display, ranging from 0 to 2 m/s. With a sleek, glass front semi-flush design, the Airflow Monitor allows for easy mounting on the hood fascia panel. The device is equipped with an audio alarm and visual red and green light indication on the front, ensuring that users are promptly alerted to any out-of-range airflow velocity.

One of the most impressive features is the ability to set independent lower and upper airflow velocity limits. If the airflow falls outside these user-defined set points, an audio and visual alarm will be triggered, alerting users to the issue. The device can also display measurements in both SI and Imperial systems.

The Airflow Monitor is designed to only show inward airflow. Outward airflow will be displayed as zero and air fail alert triggered. Additionally, the device boasts a runtime counter and reminder alerts. Users will receive reminders to calibrate the device after 4000 hours of use and settable on the device based on per day usage.

The Airflow Monitor should be produced with touch sensitive buttons. The device provides the light and fan on/off control through a contactor relay. The device also should provide air fail alert through NO NC contacts. Optionally, device shall provide analogue outputs like 0-10V or 4-20mA.

To ensure the highest level of quality and safety, the Airflow Monitor meets the ASHRAE 2016 guidelines and CE requirements of 30 & 35 derivatives. The device manufacturer should possess ISO 9001, 14001 & 45001 certificates, further demonstrating their commitment to excellence.

## Cutout and General arrangement Details

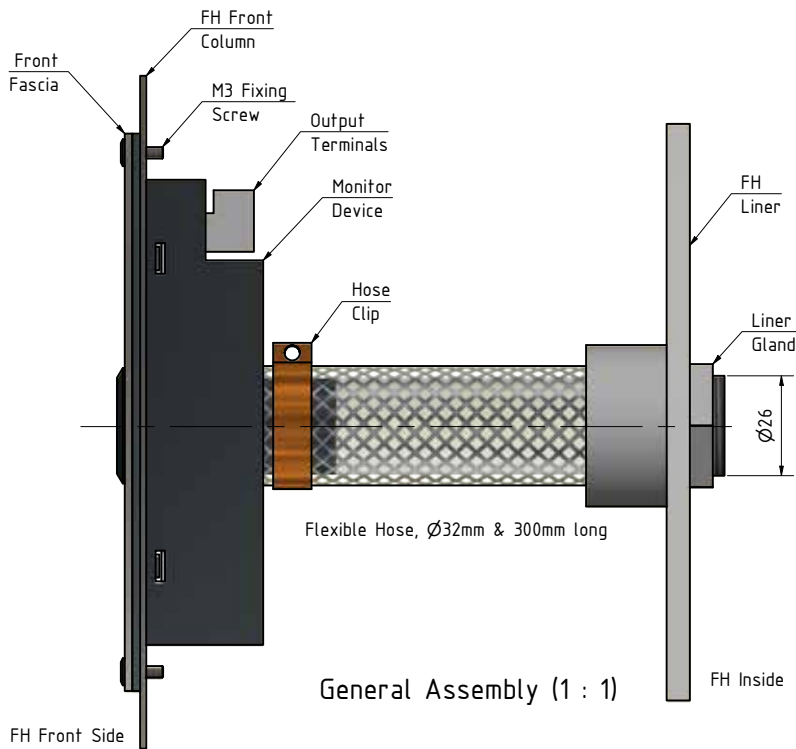

Get in touch

Please scan for real time working video



## Terminal Diagram

